

BW Weighing Indicator

General Specifications

- | | |
|--------------------------------|---|
| • Display | 52mm digit LCD display, with white LED backlight |
| • Keyboard | 7 keys (Mechanical switch) |
| • Housing | ABS plastic |
| • Max. Divisions | 6,000e; 30,000d |
| • Load cell excitation voltage | 5V/150mA |
| • ADC update | ≤1/10 second |
| • Operating Temp. | -10°C~+40°C |
| • Power | AC adapter (12V/500mA), rechargeable battery (6V/4Ah) |
| • Gross weight | 1.6kg |



- Easy to use front panel configuration
- Applications: 1. Accumulation 2. Check weighing 3. Net/gross shift
4. Weighing unit conversion 5. Peak hold 6. Animal weighing
- OIML approval from DELTA (approval no.DK0199.165)
- Keyboard lock function
- Optional RS-232 interface
- Optional analog output (0-10V/4-20mA)
- Optional setpoint output (HI/OK/LOW/BEEP)
- Optional bluetooth



BW Weighing Indicator

Model Name	Capacity	Readability	Division	Approx. weight	Approval
BW	X	X	30,000d	1.6kg	CE
BW-M	X	X	6,000e	1.6kg	CE, OIML

Options



Dimensions(mm)

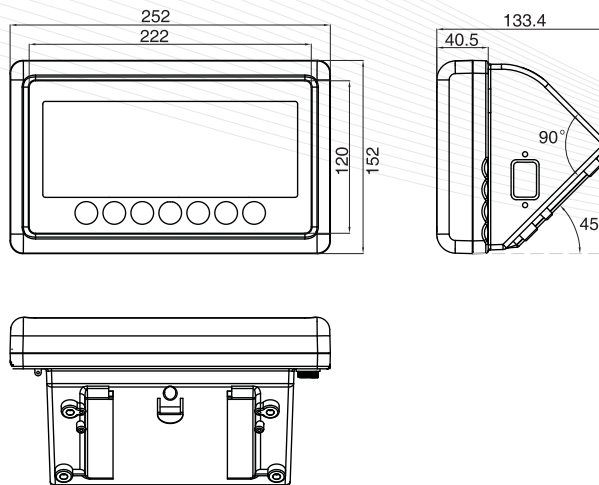

Print formats

```
NO. :      1
GS:      4.240KG
```

```
DATE: 2012/03/07
TIME: 19:06:37
NO. :      1
GS:      4.235KG
```

```
DATE: 2012/03/07
TIME: 19:08:26
NO. :      2
NT:      4.235KG
TW:      1.810KG
GW:      6.045KG
```

```
DATE: 2012/03/07
TIME: 19:10:54
TOTAL
*****
NO:      3
Total:   12.705KG
```

```
DATE: 2012/03/07
TIME: 19:09:03
NO. :      1
GS:      4.235KG
TOTAL:   4.235KG
```

```
DATE: 2012/03/07
TIME: 19:10:48
NO. :      3
NT:      4.235KG
TW:      1.810KG
GW:      6.045KG
TOTAL:  12.705KG
```