

## KW WEIGHING SCALES



### FEATURES

- large LCD display with LED backlight
- Battery provide up to 90 hours of continuous use.
- Programmable to meet your needs
- Function include counting, check weighing, animal scale, accumulation and weighing unit shift

### OPTIONAL

- Optional RS-232 communication interface, connect PC or LP-50 label printer, TPuP mini printer

### DIMENSION (mm)

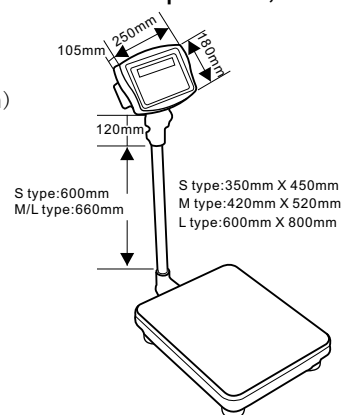

### SPECIFICATIONS

MODEL	SKW	MKW	LKW
Display	24mm LCD display, with white color LED backlight		
Operate temp	0°C~+40°C		
ADC	sigma delta		
ADC update	≤1/10 second		
Housing	indicator: ABS plastic pan: SST		
Internal counts	600,000		
Max. Divisions	1/15,000 (Max) 1/3,000 (approved)		
Keypad	7 keys membrane switch		
Power	AC adapter (9V/800mA) rechargeable battery (6V/4Ah)		
Gross weightGross	16.4kg	18.3kg	65.4kg
Packing	SKW: carton packing ,Gross weight 16.4kg dimension 0.083m <sup>3</sup> 40 feet container can load 650 machnie,20 feet container can load 325 machine MKW: carton packing ,Gross weight 18.3kg dimension 0.1m <sup>3</sup> 40 feet container can load 540 machnie,20 feet container can load 270 machine LKW: carton packing ,Gross weight 58kg dimension 0.18m <sup>3</sup> 40 feet container can load 300 machnie,20 feet container can load 150 machine		